

COMPRESSOR SOLUTIONS

LB161-LU
Mobile LPG Compressor with Diesel Engine Drive

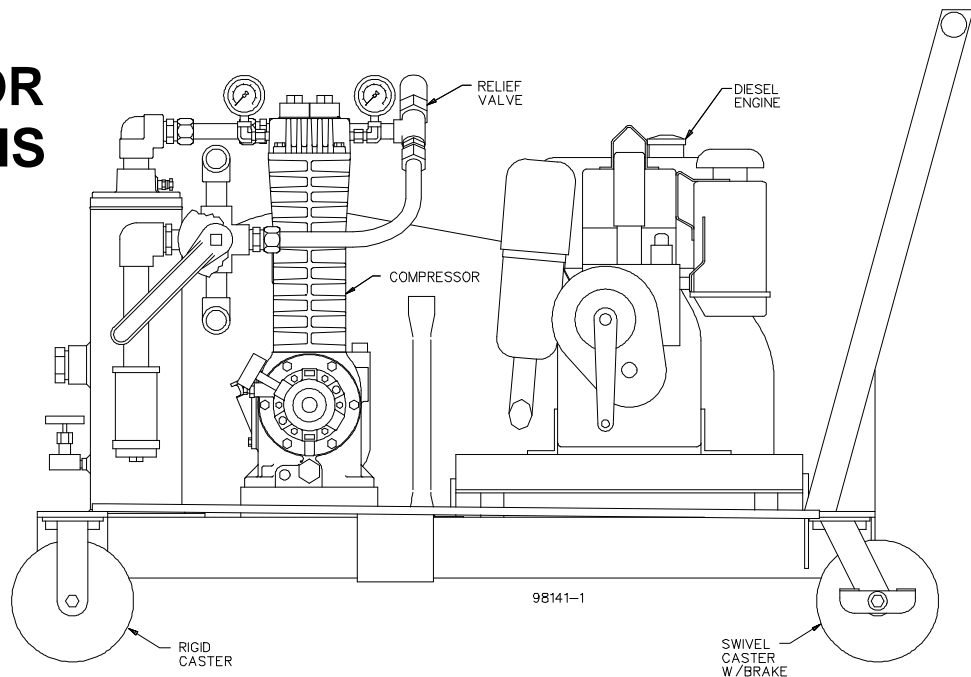

GAS
Propane
n=1.13 MW=44.1

INLET
63 - 200 psig
(4.4 - 14.1 kg/cm²g)

OUTLET
75 - 225 psig
(5.3 - 15.8 kg/cm²g)

COMPRESSOR TRIM and ACCESSORIES

Ductile Iron Cylinder
Suction Strainer
Liquid Trap with Mechanical Float

Buna-N O-rings
Discharge Relief Valve
Suction and Discharge Pressure Gauges

Casters
Oil Pressure Gauge
4-Way Flow Control Valve

DRIVER

Hatz E79 Diesel engine with crank start, clutch and spark arresting muffler.

This LB161 is to be used in Morocco as a portable LPG transfer compressor. Since the unit is engine driven and is mounted on casters, it can be easily moved to the vessel to be emptied. There it can be used to 'empty' a tank prior to moving it over public roads. It can also be used to empty vessels involved in an accident. If a liquid opening is available, the liquid may be pushed out into a bobtail or transport truck via the differential pressure method. Once the tank is emptied of liquid, the 4-way valve is reversed and the vapors are recovered.