

# COMPRESSOR SOLUTIONS

**LB942A-LC**  
For Liquefied Gas Transfer and Vapor Recovery

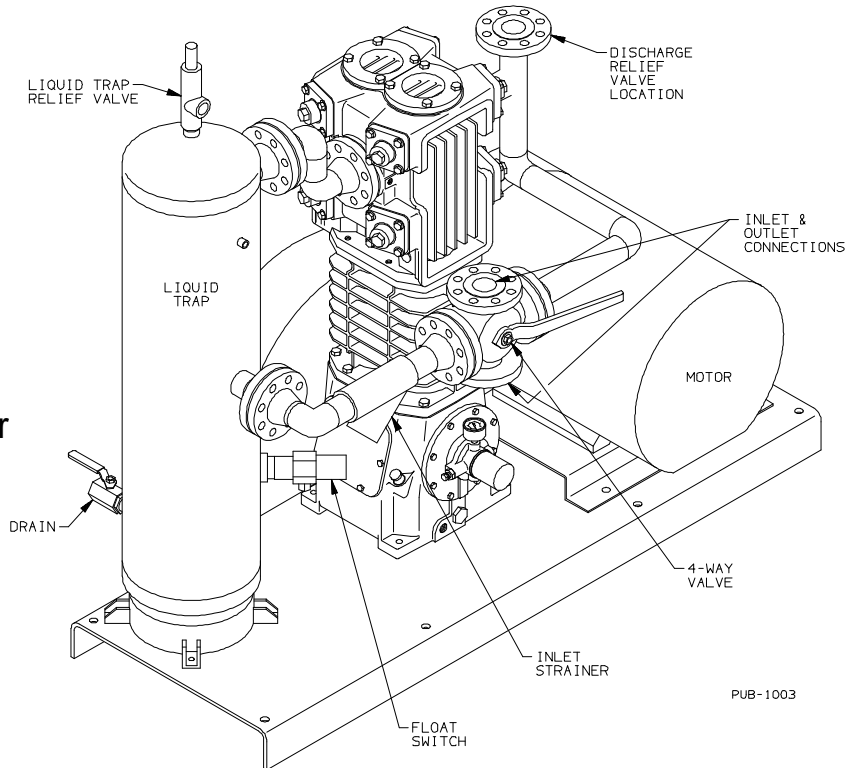

Gas	Propane C <sub>3</sub> H <sub>8</sub>	Butane C <sub>4</sub> H <sub>10</sub>	Anhydrous Ammonia NH <sub>3</sub>
MW	44.09	58.12	17.03
n Value	1.13	1.09	1.31
Vapor Pressure @ 40°F (4.4°C) @ 90°F (32.2°C)	63 psig (4.3 bar-g) 147 psig (10.1 bar-g)	3 psig (0.2 bar-g) 28 psig (1.9 bar-g)	56 psig (3.9 bar-g) 160 psig (11.0 bar-g)
Typical Transfer Rate	450 - 650 gpm 1,700 - 2,600 lpm	200 - 450 gpm 755 - 1,700 lpm	450 to 650 gpm 1,700 - 2,600 lpm
Typical Driver Size	50 HP (37 kw)	30 HP (22 kw)	50 HP (37 kw)

Compressor Trim: Ductile Iron Cylinder, Buna-N O-rings, Aluminum Gaskets  
 Driver: Electric motor, Diesel Engine or Gasoline Engine  
 Accessories: Liquid Trap with one or two electrical float switches, Suction Strainer, 4-Way Flow Control Valve, Discharge Relief Valve, Pressure Gauges for suction and discharge gas pressures and crankcase oil pressure.

The LB942A-LC is used worldwide to transfer Propane, Butane and Anhydrous Ammonia from barges, ships or multiple rail cars quietly and efficiently. The -LC mounting includes an ASME code liquid trap to prevent entry of liquid into the compressor and a 4-way flow control valve which allows vapors to be recovered after all the liquid has been transferred. Available options include pressure switches, temperature switches, trap liquid level switches, electric motors or engine drivers, and electrical control panels.