

BLACKMER PARTS LIST

PUMP MODEL: TXH35A

961831
Page 1 of 2

PARTS LIST
201-C02

Keep with Instructions 201-C00 for Installation, Operation and Maintenance

Section 201
Effective Feb 2010
Replaces Oct 2009

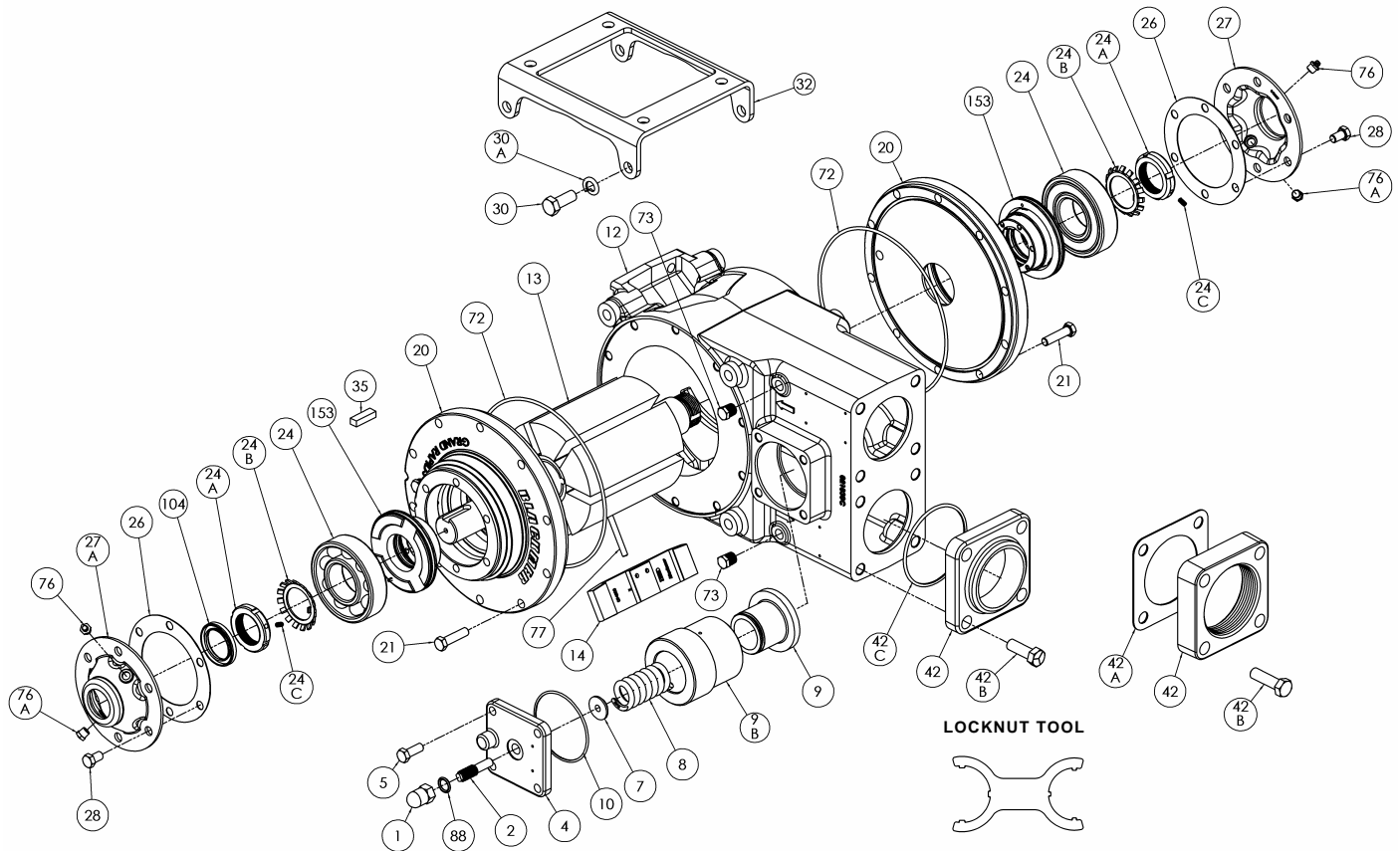

Ref. No.	Description	Parts per Pump	Part No.	Ref. No.	Description	Parts per Pump	Part No.
1	R/V Cap	1	411453	28	Capscrew	12	920285
2	Adjusting Screw - R/V	1	431800	30	Capscrew	4	981037
4	Cover-R/V	1	411800	30A	Lock Washer	4	909706
5	Capscrew	4	920331	32	Foot Bracket	1	831800
7	Spring Guide	1	423955	35	Key-Shaft (10mm Metric)	1	909146
8	Spring - R/V	1	471633		Key-Shaft (5/16" Domestic)		909206
9	Valve-R/V	1	455104	42	3" NPT Flange	0 - 2	651803
9B	Valve	1	425103		3" Weld Neck Flange		655102
10	O-Ring – FKM	1	702183	42A	Flange Gasket	0 - 2	381816
12	Cylinder	1	021830	42B	Capscrew - NPT Flange	0 - 8	920532
13	Rotor/Shaft Asy. ¹	1	261873		Capscrew - Weld Flange		920510
14	Vane - Duravane	6	094500	42C	Flange O-Ring – FKM	0 - 2	701968
20	Head	2	031815	72	O-Ring – FKM	2	711938
21	Capscrew-Head	20	920369	73	Pipe Plug	2	908198
24	Ball Bearing	2	903172	76	Grease Fitting	2	317815
24A	Locknut w/ Set Screw	2	903582	76A	Grease Relief	2	701992
24B	Lockwasher	2	903524	77	Push Rod	3	121810
24C	Set Screw	2	924060	88	Gasket	1	701981
26	Gasket, Bearing Cover	2	385125	104	Grease Seal	1	331908
27	Outboard Bearing Cover	1	041817	153	Mechanical Seal	2	See Back
27A	Inboard Bearing Cover	1	041815		Tool - Locknut		903091

¹ Includes Locknut (24A) and Lockwasher (24B)

MECHANICAL SEALS

REF. NO.	PART NAME	PARTS PER PUMP	PART NO.
153	Mechanical Seal Complete - Cast Iron Stationary Seat, FKM O-Rings, Carbon Seal Face. (IVCV)	2	331883
153D	O-Ring - Stationary (FKM)	2	711931
153L	O-Ring - Rotating (FKM)	2	701962

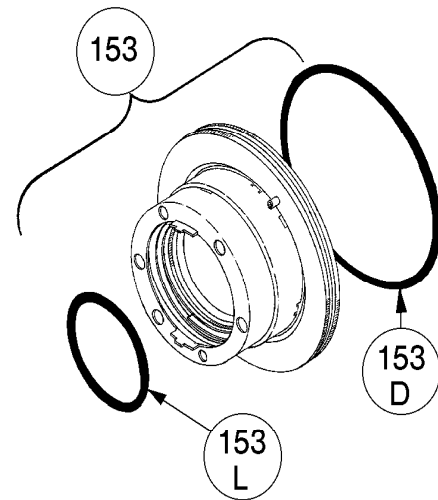

OPTIONAL HYDRAULIC MOTOR ADAPTER

REF. NO.	PART NAME	PARTS PER PUMP	PART NO.
See Below	Hydraulic Motor Adapter Kit	See Below	892229
26A	Gasket – Hydraulic Motor Adapter	1	385125
28A	Capscrew – Hydraulic Motor Adapter / head	6	920369
34	Coupling w/ Setscrew – 1.25" straight key hyd. motor shaft	1	906969
35	Key – Coupling	1	909184
76	Grease Fitting	1	317815
76A	Grease Relief Fitting	1	701992
135	Hydraulic Motor Adapter – SAE A Flange	1	041829
135A	Capscrew – Adapter / Motor	2	920510

