

BLACKMER PARTS LIST

PUMP MODELS: LGLD2E, LGL2E, LGLD3F, LGL3F

and discontinued LGLD3E, LGL3E

Keep with 501-C00 Installation, Operation and Maintenance Instructions

960418 **PARTS LIST**
Page 1 of 2 **501-C01**

Section 501
Effective May 2009
Replaces Aug 2008

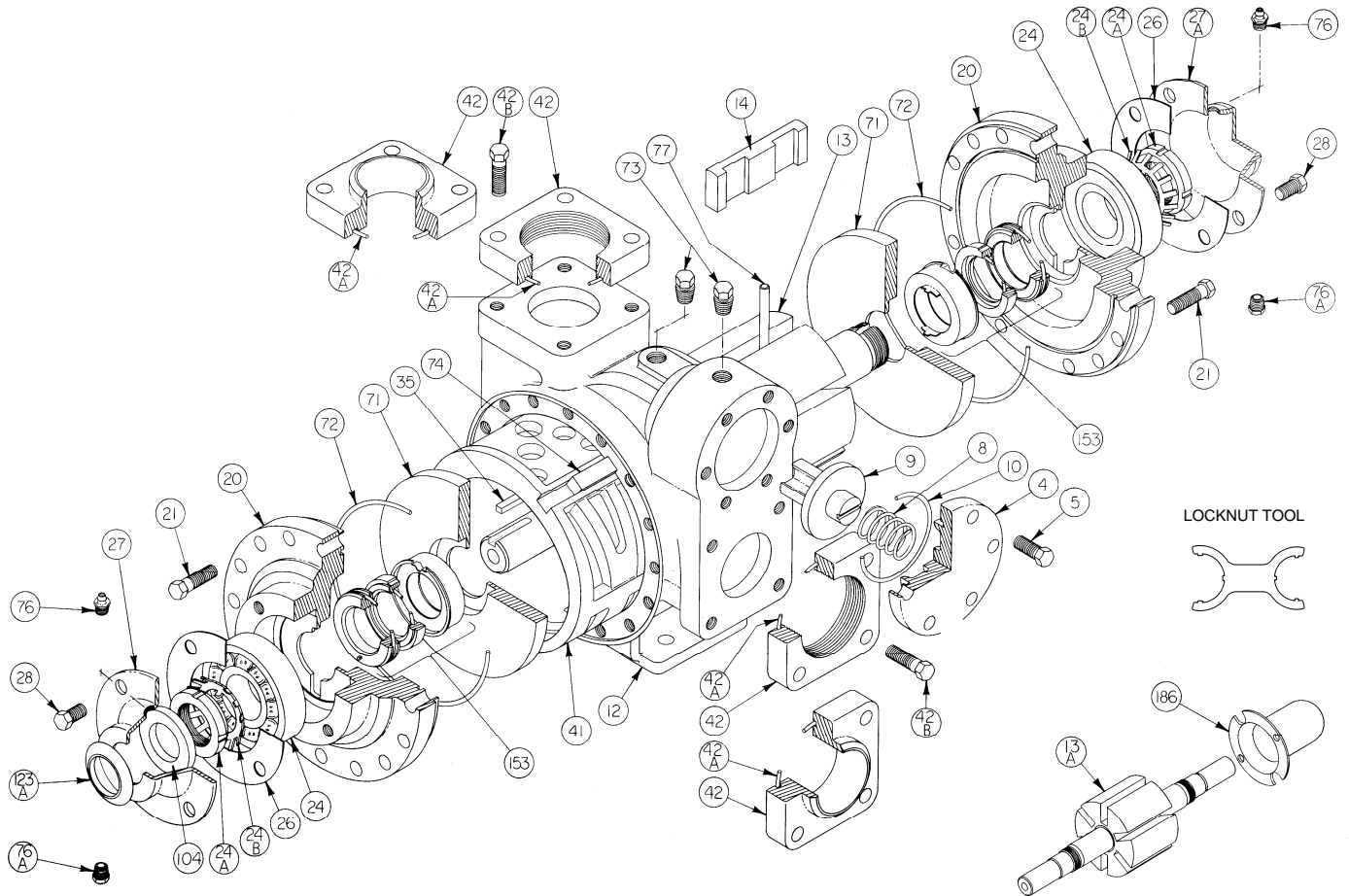

Ref. No.	Description	Parts Per Pump	Size 2 Part No.	Size 3 Part No.	Ref. No.	Description	Parts Per Pump	Size 2 Part No.	Size 3 Part No.
4	Cover - Relief Valve (R/V)	1	414401	415113	35	Key - Shaft, 1/4" Square	1	^{1,7} 909209	^{1,7} 909209
5	Capscrews - R/V Cover	6	920331	920331	41	Liner	1	² 184405	² 185111
8	Spring - R/V	1	471423	475135	42	Flange - NPT	2	654401	655112
9	Valve - R/V	1	454405	455129		Flange - Weld		654405	655102
10	O-Ring - R/V Cover	1	¹ 701919	¹ 701925	42A	O-Ring - Flange	2	¹ 702004	¹ 702002
12	Casing	1	014405	015127	42B	Capscrew - NPT Flange	8	920384	920547
13	Rotor & Shaft Asy. - LGL (Includes Ref. Nos. 24A & 24B)	1	264443	265149		Capscrew - Weld Flange		920351	920510
13A	Rotor & Shaft Asy. - LGLD ⁵ (Includes Ref. Nos. 24A & 24B)	1	² 264445	² 265148	71	Disc	2	¹ 064412	¹ 065112
14	Vane - Duravane (Std.)	6	¹ 091419	¹ 095131	72	O-Ring - Head	2	¹ 702022	¹ 702041
20	Head	2	034416	035128	73	Gage Plug	2	908198	908198
21	Capscrews - Head (Size 2)	32	920351	N/A	74	Key - Liner	1	^{2,6} 183991	² 185191
	Capscrews - Head (Size 3)	40	N/A	920369	76	Grease Fitting	2	317815	317815
24	Ball Bearing	2	¹ 903156	¹ 903166	76A	Grease Relief Fitting	2	701992	701992
24A	Locknut - Bearing	2	² 903521	² 903523	77	Push Rod, Composite	3	¹ 123905	¹ 125110
24B	Lockwasher - Bearing	2	¹ 903522	¹ 903524	104	Grease Seal	1	^{1,3} 331918	^{1,3} 331908
26	Gasket - Bearing Cover	2	¹ 383940	¹ 385125	123A	Dirt Shield	1	^{1,3} 701480	N/A
27	Bearing Cover (Inboard) ³	1	041431	041815	186	Shaft Protector (LGLD Models Only)	1	341601	341801
27A	Bearing Cover (Outboard) ⁴	1	041433	041817	—	Tool - Locknut	—	903091	903091
28	Capscrews - Bearing Cover	8 - 12	920285	920285	—	Kit - Maintenance	—	898979	898981
					—	Kit - Rebuild	—	899079	899081

¹ Included in Maintenance Kit and Rebuild Kit ² Included in Rebuild Kit
The following applies to double end shaft pumps (LGLD): ³ Use Two ⁴ Use None
⁵ Double-Ended Rotor & Shaft. ⁶ Pump before 1995 require liner key 184407.
⁷ Pumps prior to April 2008 used Woodruff key 909130, included in Maintenance kits.

MECHANICAL SEAL – NH₃ OR DUAL SERVICE – SNCN (ID Code = QA)

Ref. No.	Part Name	Parts Per Pump	Size 2 Part No.	Size 3 Part No.
153	Mechanical Seal Assembly	2	¹ 334439	¹ 335225
153A	Stationary Seat (Steel)	2	**	**
153B	Seal Face (Carbon)	2	**	**
153C	Jacket Assembly	2	**	**
153D	O-Ring - Stationary (Buna-N)	2	711924	702025
153E	O-Ring Rotating (Buna-N)	2	711918	711912

¹ Included in Maintenance Kit and Rebuild Kit

** NOTE: Mechanical Seal Ref. No. 153 is only sold as a complete assembly. Ref. Nos. 153A, 153B & 153C are not available as separate replacement parts.

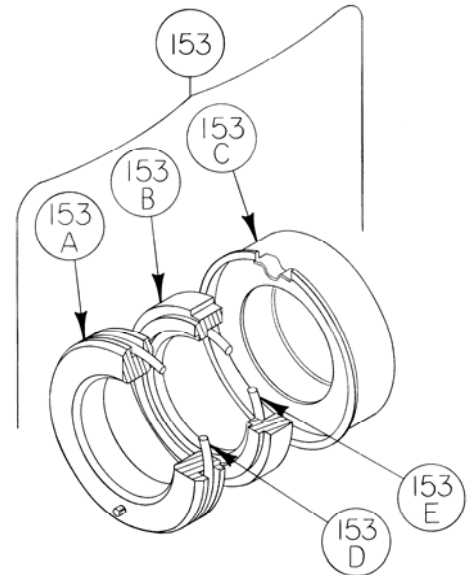

OPTIONAL HYDRAULIC MOTOR ADAPTER PARTS

Ref. No.	Part Name	Parts Per Pump	Size 2 Part No. 1-1/4" Hyd Motor Shaft	Size 3 Part No. 1-1/4" Hyd Motor Shaft	Size 3 Part No. 1" Hyd Motor Shaft
See Below	Hydraulic Motor Adapter Kit *	See Below	894425	895140	895143
26A	Gasket- Hydraulic Motor Adapter	1	383940	381817	381817
28A	Capscrew – Hydraulic Motor Adapter / Head	4 / 6	920369	920369	920369
34	Coupling w/ Setscrew – straight key hydraulic motor shaft	1	906967	906967	906990
35	Key – Coupling	1	909184	909184	909184
76	Grease Fitting	1	317185	317815	317815
76A	Grease Relief Fitting	1	701992	701992	701992
135	Hydraulic Motor Adapter – SAE A Flange	1	041827	041831	041831
135A	Capscrew – Adapter / Motor	2	920510	920510	920510

* Hydraulic Motor Adapter Kits shipped prior to Spring 2002 were of a two piece design – refer to page 206-C00.

